



COMPRESSOR COMPONENTS PISTON RINGS AND GUIDE BEARINGS

In order to guarantee best performances to the compressors, piston rings and bearing guides made up of various PTFE compounds are largely used, replacing traditional materials like cast iron, graphite and stratified structured materials.

Pure PTFE chemical inertness makes this material suitable for all the applications where high chemical resistance is required in presence of almost technical gases and fluids.

Exemptions exist in presence of alkaline metals in the molten state, fluorides and fluoridric acid in the gaseous state, and some fluorocarbons at high temperatures and pressures.

PTFE piston rings and guide bearings can be used at temperatures up to 260 °C, depending on the system pressure and piston speed this temperature limit value should be lowered. In order to improve wear resistance and to rise the working temperature limit, DuPont™Vespel®SP21 is also used to manufacture floating rings, piston rings and guide bearings. Fluorten manufactures also components in natural and filled VICTREX®PEEK for inlet and outlet valves.

Application field of piston rings and guide bearings

- Dry compressors
- Reduced lubrication compressors
- Refrigeration units
- Expansion units
- Pumps for the chemical industry
- Pumps for liquefied gases at low temperature



FLUORTEN[®]
PTFE & TECHNOPOLYMERS MANUFACTURING



COMPRESSOR COMPONENTS

PISTON RINGS AND GUIDE BEARINGS

- A** Oil scraper
- B** Piston rod
- C** Floating rings
- D** Guide bearing
- E** Piston ring
- F** Valve - inlet or outlet

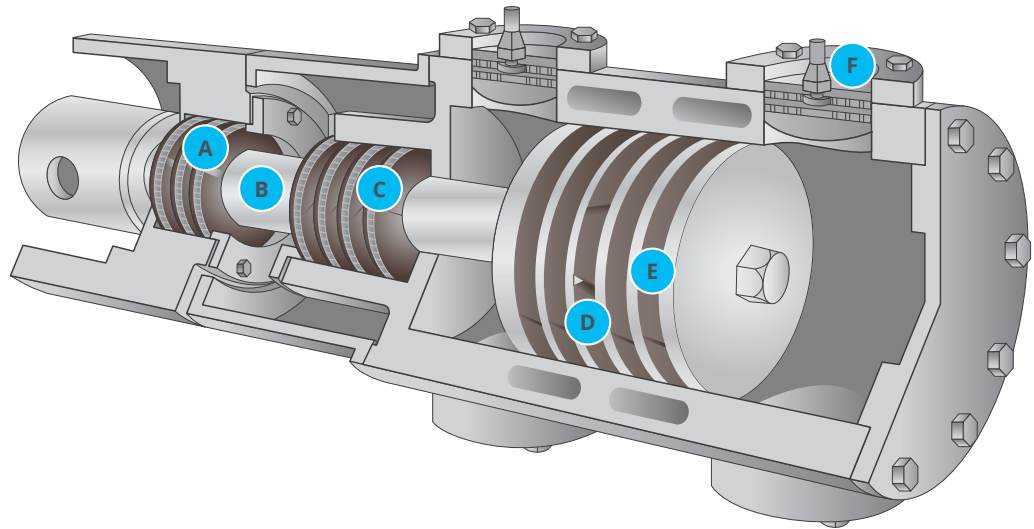

PROPERTY		Density	Tensile strenght	Elongation	Hardness	Max. operating temp.
STANDARD		ASTM D 792	ASTM D 4894	ASTM D 4894	ASTM D 2240	/
UNITS		g/cm ³	Mpa	%	Shore D	°C
TYPICAL VALUES	F10-42	2.05	14	50	67	+250
	F10-43	3.80	18	140	67	+250
	F10-53	2.27	16	100	65	+250
	F10-15 (NAT PEEK)	1.30	**90	**88	*94	+240
	F10-34 (PEEK GL)	1.49	**90	**2	*100	+240
	F10-16 (PEEK CA)	1.40	**200	**2	*107	+240
	DUPONT™ VESPEL® SP21	1.42	**62	**5.5	80	+300

F10-XX Material Norsok M-710 ED.3 and API 6A approved available on demand.

PTFE and TECHNOPYLMERS special formulations available on demand. For any further information please contact our technical office.

*Rockwell Hardness scale M in compliance with Standard ASTM D785.

**Ultimate tensile strength and Ultimate elongation in compliance with Standard ISO 527.

Whilst data and information given here are the result of our considerable experience, they are only intended as a guide line and Fluorten s.r.l. can accept no responsibility either for the results obtained from this information or for situations in conflict with any existing patents.

FLUORTEN PRODUCES:

PTFE Rulon®
Finished parts

Slipper rings
FLUOR-S/SC tapes

Spring energized seals

Compressors bearings and seals

Technopolymers injection moulding

VICTREX® PEEK/ PCTFE Semifinished products

Official italian distributor of DuPont™Vespel® trademark